

SPECIFICATION

RISING STEM. OUTSIDE SCREW AND YOKE

BS 5152 . FLANGED TO BS 4504 PN10/16, JIS10/16K, ANSI #125/150

PRESSURE/TEMPERATURE RATINGS

Working pressure	10/16 bar
Testing Pressure	Shell: 15/24 bar Seat: 11/17.6 bar
Working temperature	-10°C to 120°C
Suitable Media	Water, Oil, Gas

MATERIALS

Part	Material	BS
Body	Cast Iron	1452 Gr. 220
Bonnet	Cast Iron	1452 Gr. 220
Disc	Brass	2874 CZ122
Seat Ring	Brass	2874 CZ122
Stem/bolt/nut	Stainless steel	970 410S37
Packing	Graphite	Non-Asbestos
Handwheel	Cast Iron	1452 Gr. 220
Painting	Blue Epoxy Power Coating	

DIMENSIONS

Nominal Size mm	L mm	H mm	D mm
50	203	280	180
65	216	300	180
80	241	320	200
100	292	350	225
125	330	390	280
150	356	430	315
200	495	510	355
250	622	590	400
300	698	630	450

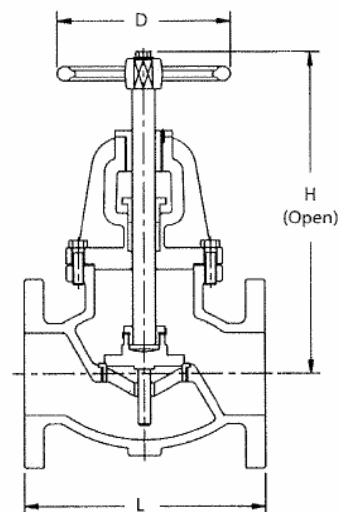

Note:

1. L: Face to face, H: Flange central to top.
2. JIS B2043 10K and other flange standards available upon request.
3. If used for gas application, please consult our sales office.
4. Design and specifications are subject to change without prior notice.